



ISDN INTERFACE TRANSFORMERS

P/N: TCG3R1A2A

Feature

- Design: according to ITU-I.430.
- Climate category: according to IEC 68-1 25/85/56.
- Dielectric strength: according to EN-60950.
- RoHS compliant.

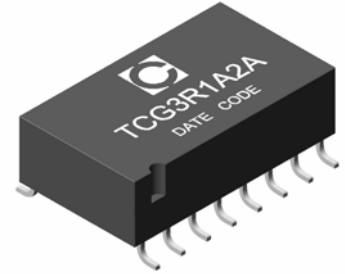

Electrical Specifications @ 25°C

Part Number	Transformer								Choke
	Ln (mH) Min	Ls (µH) Max	ΔIDC (mA)	CK (pF) Max	RLine (Ω)	RIC (Ω)	(Line IC)	Hi-pot(kV)	Ln (mH)
TCG3R1A2A	30	5	4	100	2.4	2.4	1CS : 1CS	1.5	4×5

* Operating temperature range: 0°C to +70°C. Storage temperature range: -25°C to +125°C.

Schematic

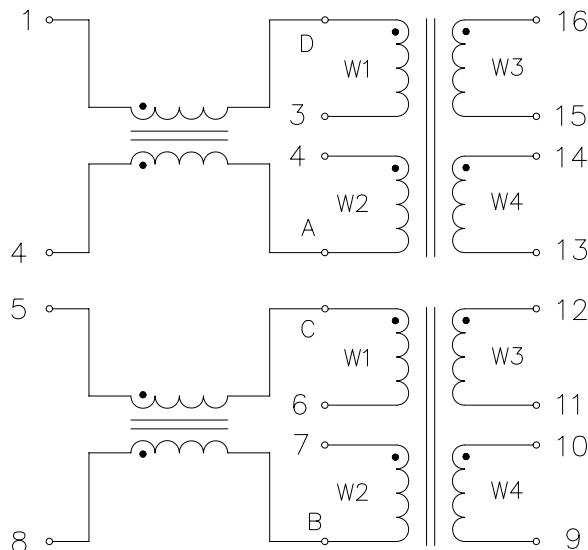

Tel:+86-20-81628973	Fax:+86-20-81628967
E-mail:sales@ceetus.com.cn	Website:www.ceetus.com.cn



ISDN INTERFACE TRANSFORMERS

P/N: TCG3R1A2A

Mechanical

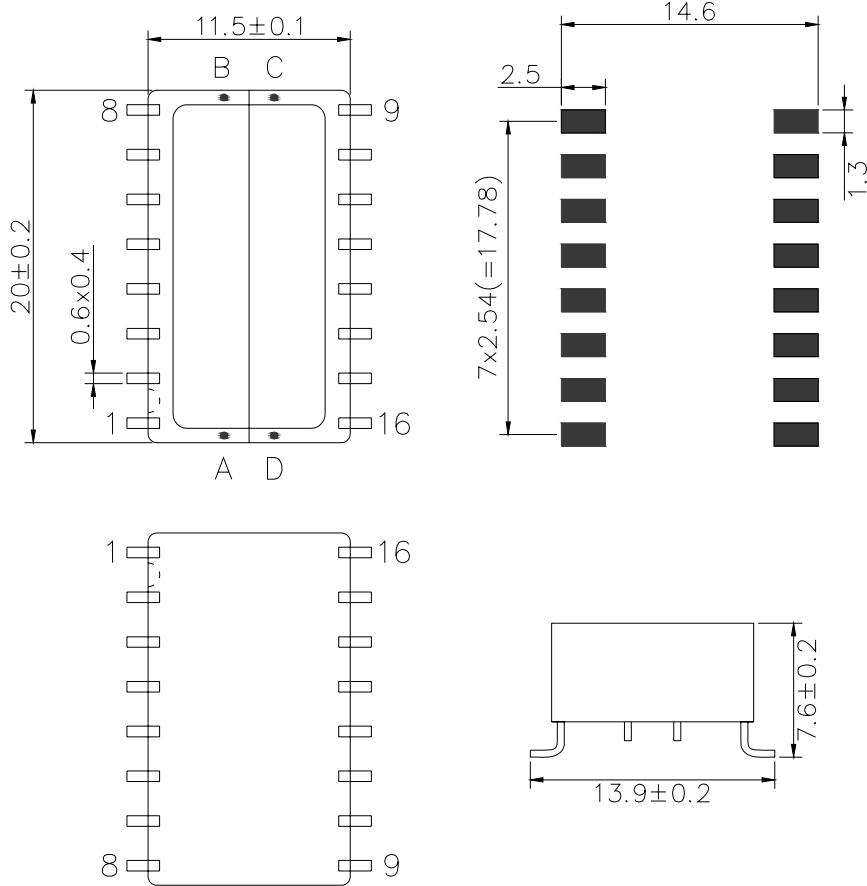

NOTE:

Datasheet Change History:

V0	2007/Mar.	Datasheet Set Up

Tel:+86-20-81628973

Fax:+86-20-81628967

E-mail:sales@ceetus.com.cn

Website:www.ceetus.com.cn